

RM100 STRAIGHT BITS
"METRIC" SIZES TWO FLUTES

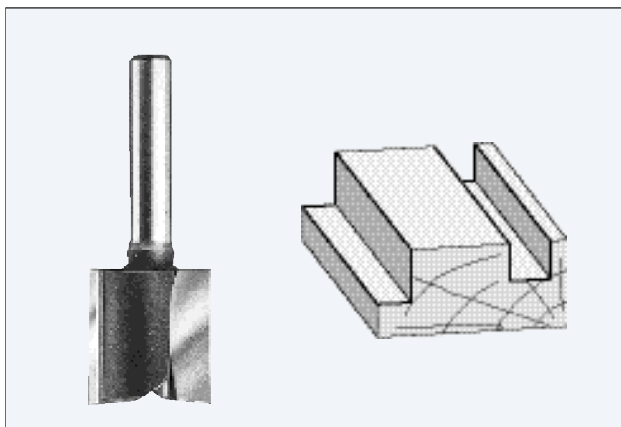

PART NO.	CUTTING DIAM.	CUTTING LENGTH	SHANK DIAM.	OVERALL LENGTH
RM100	3mm	5/16"	1/4"	1-9/16"
RM101	4mm	7/16"	1/4"	2"
RM102	5mm	7/16"	1/4"	2"
RM103	6mm	3/4"	1/4"	2"
RM104	7mm	3/4"	1/4"	2"
RM105	8mm	3/4"	1/4"	2"
RM106	8mm	1"	1/4"	2-1/4"
RM107	9mm	3/4"	1/4"	2"
RM108	10mm	3/4"	1/4"	2"
RM109	11mm	3/4"	1/4"	2"
RM110	12mm	3/4"	1/4"	2"
RM111	13mm	3/4"	1/4"	2"
RM112	14mm	3/4"	1/4"	2"
RM113	15mm	3/4"	1/4"	2"
RM114	16mm	3/4"	1/4"	2"
RM115	16mm	1-1/4"	1/4"	2-1/4"
RM116	17mm	3/4"	1/4"	2"
RM117	18mm	3/4"	1/4"	2"
RM118	19mm	3/4"	1/4"	2"
RM119	20mm	3/4"	1/4"	2"
RM120	21mm	3/4"	1/4"	2"
RM121	22mm	3/4"	1/4"	2"
RM122	25mm	3/4"	1/4"	2"

RM130 STRAIGHT BITS
"METRIC" SIZES TWO FLUTES

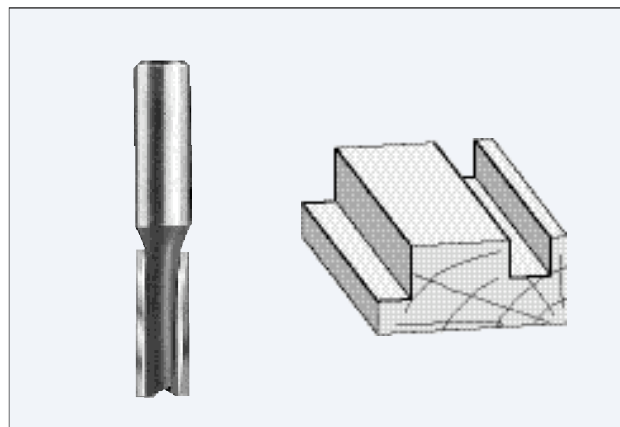

PART NO.	CUTTING DIAM.	CUTTING LENGTH	SHANK DIAM.	OVERALL LENGTH
RM130	6mm	3/4"	1/2"	2-1/2"
RM131	8mm	1"	1/2"	2-5/8"
RM132	10mm	1"	1/2"	2-1/2"
RM133	10mm	1-1/4"	1/2"	3"
RM134	12mm	1"	1/2"	2-5/8"
RM135	12mm	1-1/4"	1/2"	2-7/8"
RM136	12mm	1-1/2"	1/2"	3"
RM137	12mm	2"	1/2"	4-1/4"
RM138	14mm	1"	1/2"	2-5/8"
RM140	16mm	1"	1/2"	2-5/8"
RM141	16mm	1-1/4"	1/2"	2-7/8"
RM142	16mm	1-1/2"	1/2"	3-1/8"
RM143	18mm	1-1/4"	1/2"	2-7/8"
RM144	19mm	1"	1/2"	2-5/8"
RM145	19mm	1-1/4"	1/2"	2-7/8"
RM146	19mm	1-1/2"	1/2"	3-1/8"
RM147	20mm	1"	1/2"	2-5/8"
RM148	20mm	1-1/4"	1/2"	2-7/8"
RM149	22mm	1"	1/2"	2-5/8"
RM150	25mm	1-1/4"	1/2"	2-7/8"
RM151	25mm	1-1/2"	1/2"	3-1/8"
RM152	27mm	1-1/4"	1/2"	2-7/8"
RM153	30mm	1"	1/2"	2-5/8"
RM154	35mm	1"	1/2"	2-5/8"
RM155	40mm	1-1/4"	1/2"	2-7/8"
RM156	51mm	1-1/4"	1/2"	2-7/8"

R1000 1/4" SHANK STRAIGHT
ROUTER BITS SOLID CARBIDE

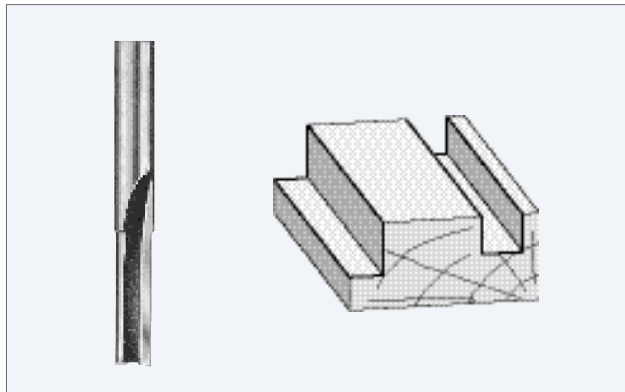

PART NO.	CUTTING DIAM.	CUTTING LENGTH	SHANK LENGTH	NO. FLUTE	OVERALL LENGTH
R1000	1/8"	3/8"	1"	1	1-1/2"
R1008	7/32"	3/4"	1"	1	2"
R1100	1/8"	3/8"	1"	2	1-1/2"
R1104	5/32"	5/8"	1"	2	1-1/2"
R1106	3/16"	5/8"	1-1/4"	2	2"
R1108	7/32"	3/4"	1-1/4"	2	2"
R1110	1/4"	3/4"	1-1/4"	2	2"
R1112	1/4"	1"	1-1/4"	2	2-1/2"

R2000 1/4" SHANK
STRAIGHT ROUTER BITS ONE FLUTE

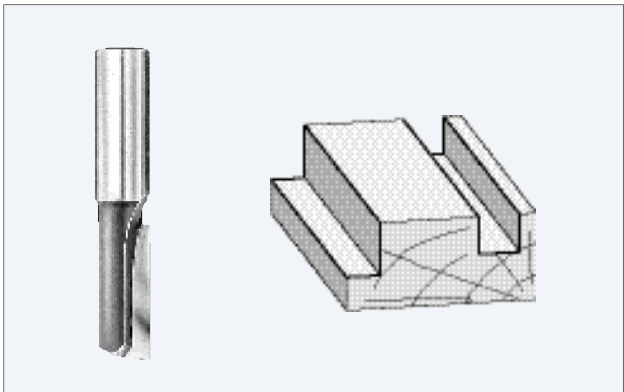

PART NO.	CUTTING DIAM.	CUTTING LENGTH	SHANK LENGTH	OVERALL LENGTH
R2000	1/8"	7/16"	1-1/4"	2"
R2000-1	5/32"	7/16"	1-5/16"	2"
R2001*	3/16"	7/16"	1-1/4"	2"
R2003	1/4"	1/2"	1-9/16"	2"
R2004	1/4"	3/4"	1-1/4"	2"
R2005*	1/4"	1"	1-1/4"	2-1/4"
R2006	9/32"	3/4"	1"	2"
R2008	5/16"	1"	1"	2-1/4"
R2008-1	3/8"	3/4"	1"	1-15/16"
R2008-2	3/8"	1"	1-1/8"	2-3/8"
R2008-3	1/2"	3/4"	1"	1-3/4"
R2008-4	1/2"	1"	1"	2-1/8"
R2008-5	5/8"	3/4"	1"	1-15/16"
R2008-6	3/4"	3/4"	1"	1-3/4"

R1302 STRAIGHT ROUTER BITS
TWO FLUTES SOLID CARBIDE

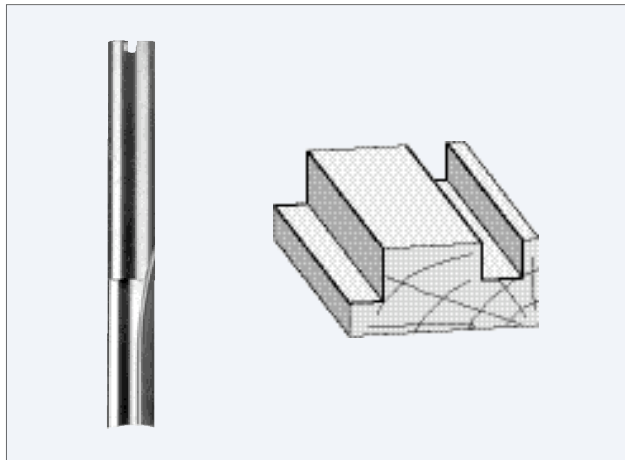

PART NO.	CUTTING DIAM.	CUTTING LENGTH	SHANK DIAM.	SHANK LENGTH	OVERALL LENGTH
R1302	3/8"	1"	3/8"	1-3/4"	3"
R1304	1/4"	3/4"	1/2"	1-1/4"	3"
R1306	1/4"	1"	1/2"	2"	3"
R1308	5/16"	1"	1/2"	2"	3"

* Not guaranteed due to extreme length and/or fragility

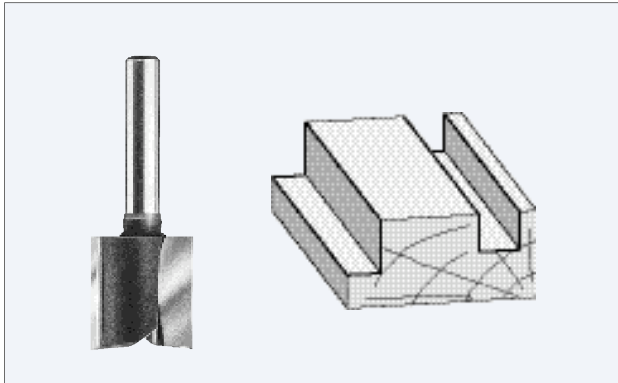
R2009
**1/4" SHANK STRAIGHT ROUTER BITS
TWO FLUTES**

PART NO.	CUTTING DIAM.	CUTTING LENGTH	SHANK LENGTH	OVERALL LENGTH
R2009-1 *	1/16"	3/16"	1-3/8"	1-7/8"
R2009-2	3/32"	1/4"	1-5/8"	1-7/8"
R2010	1/8"	7/16"	1-1/4"	2"
R2010-1	5/32"	7/16"	1-9/16"	2"
R2011	3/16"	7/16"	1-1/4"	2"
R2011-1	3/16"	5/8"	1-1/8"	2-1/8"
R2011-2	7/32"	3/4"	1-7/16"	1-7/8"
R2012	1/4"	1/2"	1-1/4"	2"
R2013	1/4"	3/4"	1-1/4"	2"
R2014*	1/4"	1"	1-1/4"	2-1/4"
R2017	9/32"	3/4"	1-1/4"	2"
R2017-1	9/32"	1"	1-1/8"	2-1/4"
R2018	5/16"	3/4"	1-1/8"	2"
R2019	5/16"	1"	1-1/4"	2-1/4"
R2021	3/8"	3/4"	1-1/4"	2"
R2022	3/8"	1"	1-1/4"	2-1/4"
R2023	3/8"	1-1/4"	1-1/4"	2-1/2"
R2023-1	7/16"	3/4"	1-1/8"	2"
R2024	7/16"	1"	1-1/4"	2-1/8"
R2025	1/2"	3/4"	1-1/4"	2"
R2026	1/2"	1"	1-1/4"	2-1/8"
R2026-1	1/2"	1-1/4"	1-1/8"	2-1/2"
R2027	9/16"	3/4"	1-1/4"	2-1/8"
R2027-1	9/16"	1"	1-3/8"	2-1/2"
R2028	5/8"	3/4"	1-1/4"	2"
R2028-1	5/8"	1"	1-1/8"	2-1/4"
R2029	11/16"	3/4"	1-1/4"	2"
R2029-1	11/16"	1"	1-1/8"	2-1/4"
R2030	3/4"	3/4"	1-1/4"	2"
R2030-1	3/4"	1"	1-1/8"	2-1/4"
R2031	13/16"	3/4"	1-1/4"	2"
R2032	7/8"	3/4"	1-1/4"	2"
R2032-1	15/16"	3/4"	1-1/8"	2"
R2033	1"	3/4"	1-1/4"	2"

* Not guaranteed due to extreme length and/or fragility

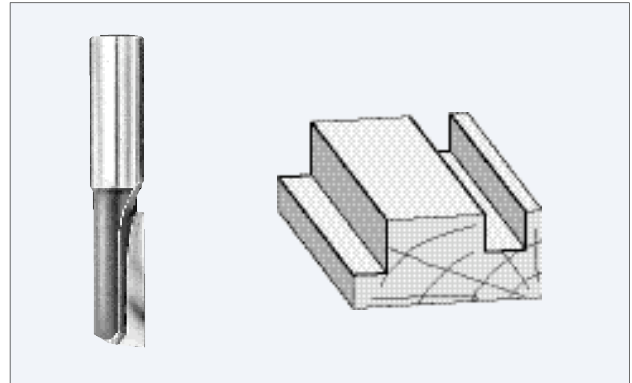
R2034
**3/8" SHANK
STRAIGHT ROUTER BITS ONE FLUTE**

PART NO.	CUTTING DIAM.	CUTTING LENGTH	SHANK LENGTH	OVERALL LENGTH
R2034	1/4"	3/4"	1-1/4"	2-1/4"
R2034-1	3/8"	1"	1-1/4"	2-11/16"
R2034-2	3/8"	1-1/4"	1-1/4"	2-5/8"

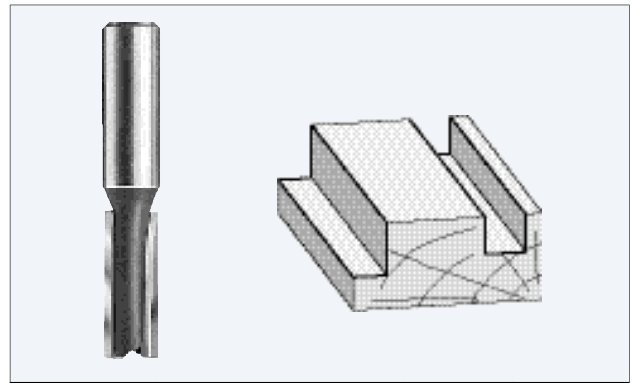
R2035
**3/8" SHANK STRAIGHT ROUTER BITS
TWO FLUTES**

PART NO.	CUTTING DIAM.	CUTTING LENGTH	SHANK LENGTH	OVERALL LENGTH
R2035	1/8"	7/16"	1-1/4"	2"
R2035-1	5/32"	7/16"	1-1/4"	2"
R2037	1/4"	3/4"	1-3/8"	2-1/4"
R2038	5/16"	1"	1-3/8"	2-1/2"

3/8" Shank Router Bits cont'd...



R2038-1 3/8" SHANK STRAIGHT ROUTER BITS TWO FLUTES cont'd...

PART NO.	CUTTING DIAM.	CUTTING LENGTH	SHANK LENGTH	OVERALL LENGTH
R2038-1	3/8"	3/4"	1-1/2"	2-1/4"
R2039	3/8"	1"	1-3/8"	2-1/2"
R2040	3/8"	1-1/4"	1-3/8"	2-3/4"
R2042	7/16"	1"	1-1/4"	2-1/2"
R2043	1/2"	1"	1-1/4"	2-1/2"
R2043-1	1/2"	1-1/4"	1-1/4"	2-1/2"
R2043-3	5/8"	3/4"	1-1/4"	2-1/4"
R2043-5	13/16"	3/4"	1-1/4"	2-1/4"
R2043-6	7/8"	3/4"	1-1/4"	2-1/4"
R2043-7	1"	3/4"	1-1/4"	2-1/4"

R2044 1/2" SHANK STRAIGHT ROUTER BITS ONE FLUTE

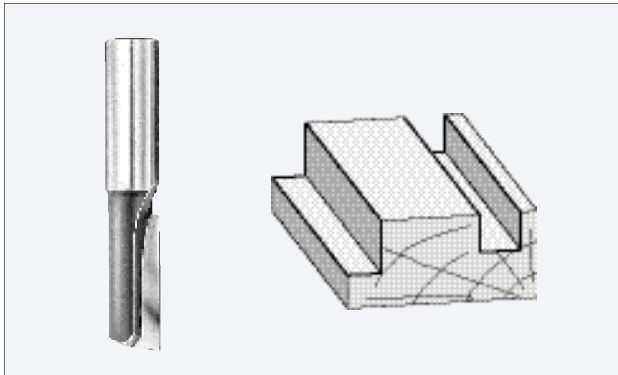

PART NO.	CUTTING DIAM.	CUTTING LENGTH	SHANK LENGTH	OVERALL LENGTH
R2044*	1/4"	3/4"	1-3/8"	2-1/2"
R2045*	1/4"	1"	1-1/4"	2-1/2"
R2047	5/16"	1"	1-1/2"	2-3/4"
R2049	3/8"	1"	1-3/8"	2-1/2"
R2050*	3/8"	1-1/4"	1-3/8"	2-3/4"
R2051	1/2"	1"	1-1/4"	2-1/2"
R2052	1/2"	1-1/4"	1-3/8"	2-7/8"
R2054	1/2"	1-1/2"	1-3/8"	3-1/8"
R2055	1/2"	2"	1-7/8"	4-1/4"
R2056	9/16"	1-1/4"	1-1/4"	2-7/8"
R2057	5/8"	1-1/4"	1-1/4"	2-7/8"

* Not guaranteed due to extreme length and/or fragility

R2057 1/2" SHANK STRAIGHT ROUTER BITS TWO FLUTES

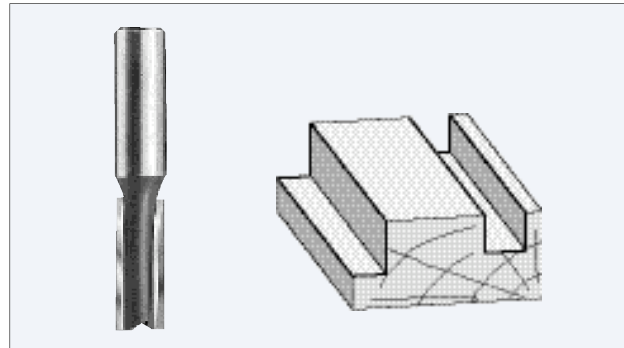

PART NO.	CUTTING DIAM.	CUTTING LENGTH	SHANK LENGTH	OVERALL LENGTH
R2057-0	15/64"	3/4"	1-3/8"	2-1/2"
R2057-1*	1/4"	1/2"	1-3/8"	2"
R2058*	1/4"	3/4"	1-3/8"	2-1/2"
R2058-1*	1/4"	1"	1-3/8"	2-1/2"
R2059	5/16"	3/4"	1-3/8"	2-1/2"
R2060*	5/16"	1"	1-3/8"	2-1/2"
R2061	3/8"	3/4"	1-3/8"	2-1/2"
R2062	3/8"	1"	1-3/8"	2-1/2"
R2063*	3/8"	1-1/4"	1-3/8"	2-3/4"
R2063A	13/32"	1"	1-3/8"	2-3/4"
R2064	7/16"	1"	1-1/4"	2-5/8"
R2065	7/16"	1-1/4"	1-3/8"	2-3/4"
R2065-1	31/64"	1"	1-3/8"	2-5/8"
R2066	1/2"	1"	1-3/8"	2-5/8"
R2067	1/2"	1-1/4"	1-3/8"	2-7/8"
R2069	1/2"	1-1/2"	1-3/8"	3"
R2070	1/2"	1-1/2"	2-1/2"	4-1/4"
R2071*	1/2"	2"	1-7/8"	4-1/4"
R2072*	1/2"	2-1/2"	1-7/8"	4-1/2"
R2074	17/32"	1-1/4"	1-3/8"	2-7/8"
R2074-1	9/16"	1"	1-3/8"	2-5/8"
R2075	9/16"	1-1/4"	1-3/8"	2-7/8"
R2076	5/8"	1"	1-3/8"	2-5/8"
R2077	5/8"	1-1/4"	1-3/8"	2-7/8"
R2078	5/8"	1-1/2"	1-3/8"	3"
R2079	5/8"	2"	1-7/8"	3-5/8"
R2081	21/32"	1-1/4"	1-3/8"	2-7/8"
R2083	11/16"	1-1/4"	1-3/8"	2-7/8"
R2083-1	23/32"	1-1/4"	1-3/8"	2-7/8"
R2084	3/4"	1"	1-3/8"	2-5/8"
R2085	3/4"	1-1/4"	1-3/8"	2-7/8"
R2086	3/4"	1-1/2"	1-3/8"	3"
R2087	3/4"	2"	1-3/8"	3-5/8"
R2088	25/32"	1-1/4"	1-3/8"	2-7/8"

1/2" Shank Router Bits cont'd...



R2089 1/2" SHANK STRAIGHT ROUTER
BITS TWO FLUTES cont'd

PART NO.	CUTTING DIAM.	CUTTING LENGTH	SHANK LENGTH	OVERALL LENGTH
R2089	13/16"	1"	1-3/8"	2-5/8"
R2090	13/16"	1-1/4"	1-3/8"	2-7/8"
R2090-1	7/8"	1"	1-3/8"	2-5/8"
R2091	7/8"	1-1/4"	1-3/8"	2-7/8"
R2092	15/16"	1-1/4"	1-3/8"	2-7/8"
R2092-1	1"	1"	1-3/8"	2-5/8"
R2093	1"	1-1/4"	1-3/8"	2-7/8"
R2093-1	1"	1-1/2"	1-1/4"	3"
R2093-2	1"	2"	1-3/8"	3-5/8"
R2094	1-1/16"	1-1/4"	1-3/8"	2-7/8"
R2095	1-3/16"	1-1/4"	1-3/8"	2-7/8"
R2096	1-1/8"	1-1/4"	1-3/8"	2-7/8"
R2097	1-1/4"	1-1/4"	1-3/8"	2-7/8"
R2098	1-3/8"	1-1/4"	1-3/8"	2-7/8"
R2099	1-1/2"	1-1/4"	1-3/8"	2-7/8"
R2099-1	1-5/8"	1-1/4"	1-3/8"	2-7/8"
R2100	1-3/4"	1-1/4"	1-3/8"	2-7/8"
R2100-1	1-7/8"	1-1/4"	1-3/8"	2-7/8"
R2101	2"	1-1/4"	1-3/8"	2-7/8"

R2150 3/4" SHANK
STRAIGHT ROUTER BITS TWO FLUTES

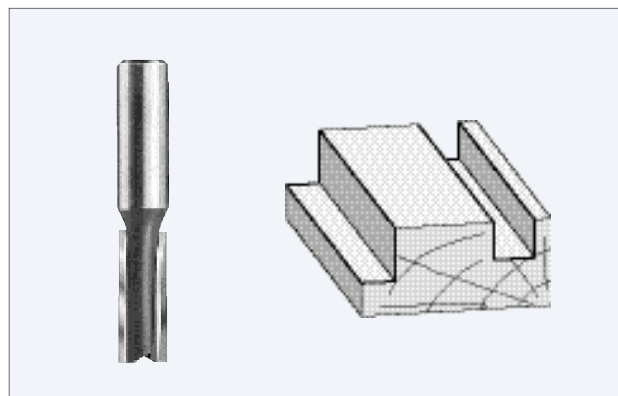

PART NO.	CUTTING DIAM.	CUTTING LENGTH	SHANK LENGTH	OVERALL LENGTH
R2150	3/4"	1-1/4"	1-1/2"	3"
R2151	3/4"	1-1/2"	1-1/2"	3-1/4"
R2152	3/4"	2"	1-3/4"	4"
R2153	3/4"	2-1/2"	2"	4-1/2"
R2158	1"	1-1/2"	1-1/2"	3-1/4"
R2160	1"	2"	2"	4-1/4"

R2110 1/2" SHANK
STRAIGHT ROUTER BITS
TWO FLUTES DOWN SHEAR

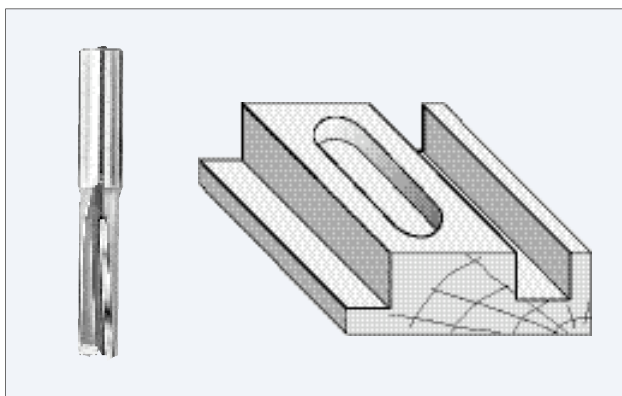

PART NO.	CUTTING DIAM.	CUTTING LENGTH	SHANK LENGTH	OVERALL LENGTH
R2110	3/8"	1"	1-1/2"	2-3/4"
R2111	1/2"	1-1/4"	1-1/4"	2-7/8"
R2112	1/2"	1-1/2"	1-3/8"	3-1/8"
R2113	1/2"	2"	2"	4-1/4"

R2200 STAGGER TOOTH
STRAIGHT ROUTER BITS

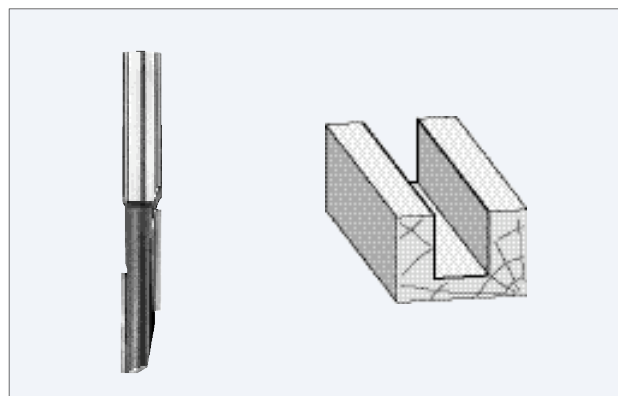

PART NO.	CUTTING DIAM.	CUTTING LENGTH	SHANK DIAM.	SHANK LENGTH	OVERALL LENGTH
R2200S	1/4"	1"	1/4"	1-1/2"	2-1/4"
R2200	3/8"	1-3/8"	3/8"	1-1/4"	3"
R2201	3/8"	1-1/2"	1/2"	1-3/8"	3-1/8"
R2202	1/2"	1-1/2"	1/2"	1-3/8"	3-1/8"
R2203	1/2"	2"	1/2"	1-5/8"	4-1/4"
R2203-1	1/2"	2-1/8"	1/2"	1-5/8"	4-1/4"

R2206 STAGGER TOOTH BITS WITH COMPRESSION SHEAR

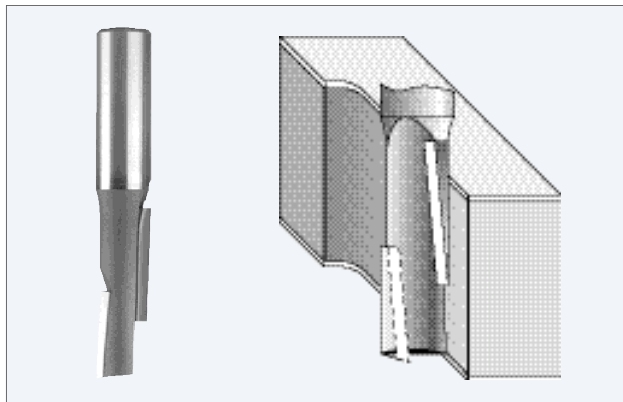

PART NO.	CUTTING DIAM.	CUTTING LENGTH	SHANK DIAM.	SHANK LENGTH	OVERALL LENGTH
R2206	1/2"	1-1/2"	1/2"	1-5/8"	3-1/8"
R2207	1/2"	2"	1/2"	2"	4-1/4"

R2210 LEFT HAND ROUTER BITS 1/2" SHANK TWO FLUTES

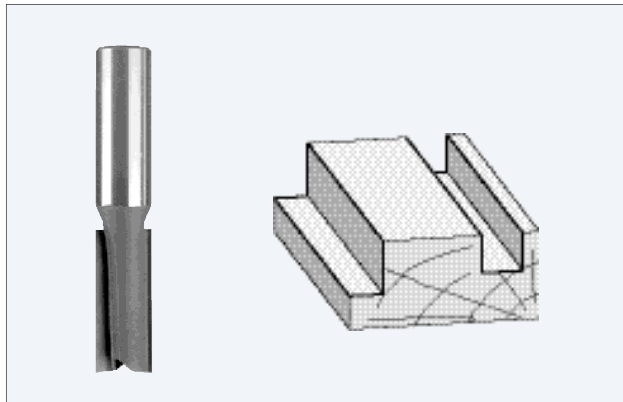

PART NO.	CUTTING DIAM.	CUTTING LENGTH	SHANK LENGTH	OVERALL LENGTH
R2210	5/16"	3/4"	1-3/8"	2-1/2"
R2211	5/16"	1"	1-3/8"	2-3/4"
R2212	3/8"	1"	1-3/8"	2-3/4"
R2213	7/16"	1-1/4"	1-1/4"	3"
R2214	1/2"	1-1/4"	1-3/8"	2-7/8"
R2215	1/2"	1-1/2"	1-3/8"	3"
R2216	1/2"	2"	1-7/8"	4-1/4"
R2217	9/16"	1-1/4"	1-3/8"	2-7/8"
R2218	5/8"	1-1/4"	1-3/8"	2-7/8"
R2219	3/4"	1-1/4"	1-3/8"	2-7/8"
R2220	3/4"	2"	1-3/8"	3-5/8"
R2221	13/16"	1-1/4"	1-3/8"	2-7/8"
R2222	7/8"	1-1/4"	1-3/8"	2-7/8"
R2223	1"	1-1/4"	1-3/8"	2-7/8"

R2230 PLUNGE POINT BITS 1/4" SHANK TWO FLUTES

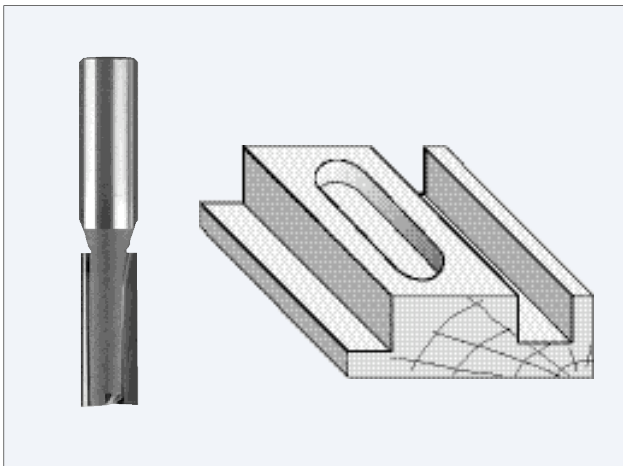

PART NO.	CUTTING DIAM.	CUTTING LENGTH	SHANK LENGTH	OVERALL LENGTH
R2230	5/16"	3/4"	1-1/8"	2"
R2231	3/8"	3/4"	1-1/8"	2"
R2232	3/8"	1"	1-1/8"	2-1/4"
R2233	1/2"	3/4"	1-1/8"	2"
R2234	1/2"	1"	1-1/8"	2-1/8"
R2235	5/8"	3/4"	1-1/8"	2"
R2236	7/8"	3/4"	1-1/8"	2"
R2237	1"	3/4"	1-1/8"	2"

All above bits supplied with **bottom carbide** for **plunging** operations.

R2240 PLUNGE POINT BITS
1/2" SHANK TWO FLUTES

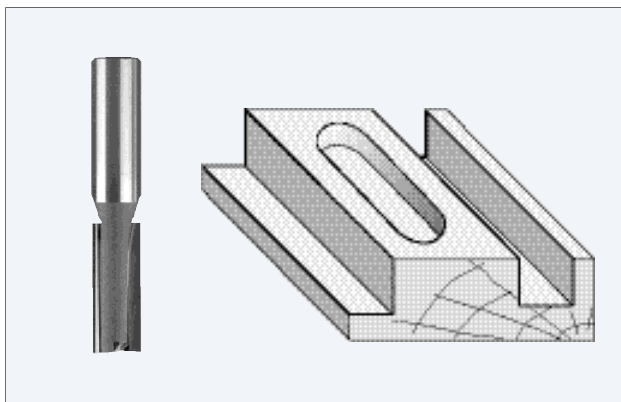

PART NO.	CUTTING DIAM.	CUTTING LENGTH	SHANK LENGTH	OVERALL LENGTH
R2240	5/16"	3/4"	1-3/8"	2-1/2"
R2241	3/8"	1-1/4"	1-1/2"	3"
R2242	7/16"	1"	1-1/4"	2-3/4"
R2243	1/2"	1"	1-3/8"	2-5/8"
R2244	1/2"	1-1/4"	1-3/8"	2-7/8"
R2245	1/2"	1-1/2"	1-3/8"	3-1/8"
R2246	1/2"	2"	1-7/8"	4-1/4"
R2247	5/8"	1-1/4"	1-3/8"	2-7/8"
R2248	5/8"	2"	1-7/8"	3-3/4"
R2249	3/4"	1"	1-3/8"	2-5/8"
R2250	7/8"	1-1/4"	1-3/8"	2-7/8"
R2251	1"	1"	1-3/8"	2-5/8"
R2252	1-5/8"	1"	1-3/8"	2-5/8"
R2253	1-3/4"	1-1/4"	1-3/8"	2-7/8"
R2254	1-7/8"	1-1/4"	1-3/8"	2-7/8"

AR15MB THREADED ARBOR
FOR MORTISING BITS



PART NO.	SHANK DIAM.	TYPE OF THREAD	OVERALL LENGTH
AR12MB	1/2"	1/4-28	2-3/8"
AR14MB	1/4"	1/4-28	1-3/4"

Fits R2310 to R2314 mortising bits, screw type.

R2300 MORTISING BITS
TWO FLUTES

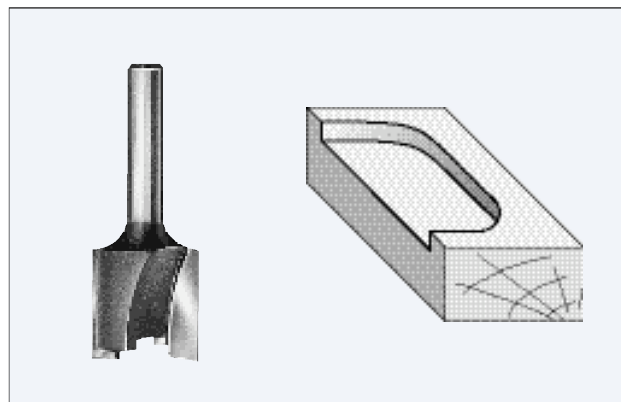

PART NO.	CUTTING DIAM.	CUTTING LENGTH	SHANK DIAM.	SHANK LENGTH	OVERALL LENGTH
R2300	1/2"	3/4"	1/4"	1-1/4"	2"
R2301	5/8"	3/4"	1/4"	1-1/4"	2"
R2302	3/4"	3/4"	1/4"	1-1/4"	2"
R2303	1"	3/4"	1/4"	1-1/8"	2"
R2304	1-1/4"	1/2"	1/4"	1-1/4"	1-3/4"
R2305	1-1/4"	1-1/4"	1/2"	1-1/4"	2-7/8"

R2310 MORTISING BITS
SCREW TYPE TWO FLUTES

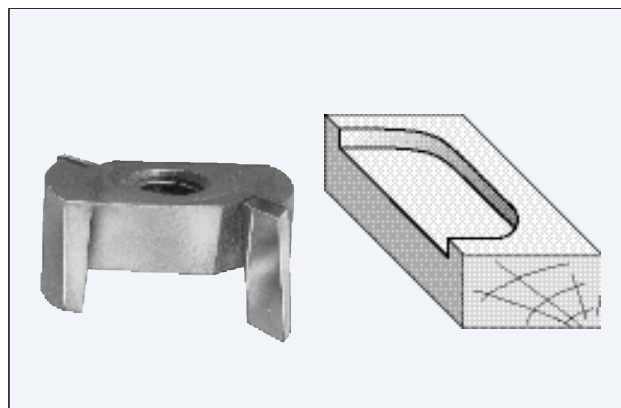

PART NO.	CUTTING DIAM.	THREADED HOLE	CUTTING LENGTH
R2310	3/4"	1/4-28 Thread	1/2"
R2311	7/8"	1/4-28 Thread	1/2"
R2312	1"	1/4-28 Thread	1/2"
R2313	1-1/8"	1/4-28 Thread	9/16"
R2314	1-1/4"	1/4-28 Thread	5/8"

R2631 TEE/BUMPER MOULDING GROOVING BITS TWO FLUTES

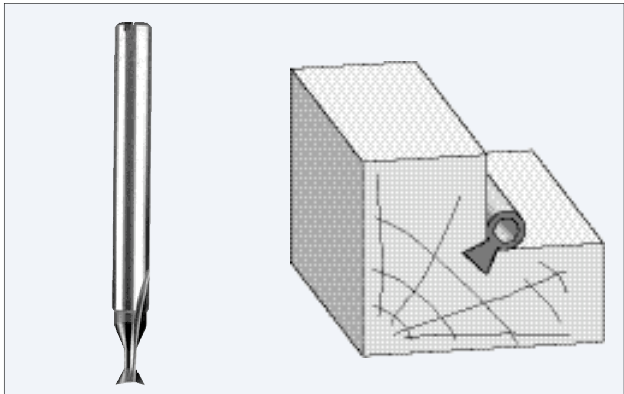

PART NO.	LARGE DIAM.	DEGREES EA. SIDE	DEPTH OF CUT	SHANK DIAM.	OVERALL LENGTH
R2631	13/64"	25°	5/32"	1/4"	2-3/8"

R2632 TEE/BUMPER MOULDING GROOVING BITS TWO FLUTES

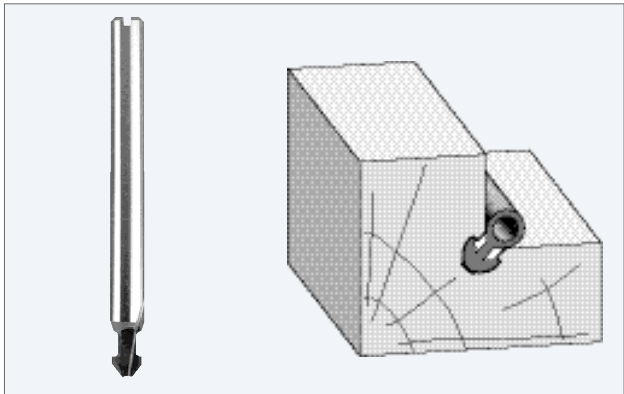

PART NO.	LARGE DIAM.	SMALL DIAM.	DEGREES EA. SIDE	DEPTH OF CUT	SHANK DIAM.	OVERALL LENGTH
R2632	7/32"	5/64"	38°	5/16"	1/4"	2-9/16"

R2700 PANEL PILOT BITS WITH PLUNGE POINT

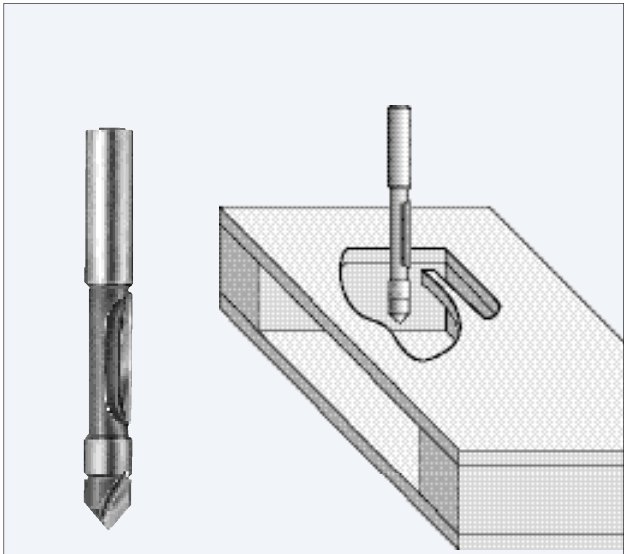

PART NO.	CUTTING DIAM.	CUTTING LENGTH	SHANK DIAM.	FLUTES	OVERALL LENGTH
R2700	1/4"	3/4"	1/4"	1	2-1/2"
R2701	3/8"	1"	3/8"	1	3"
R2702	1/2"	1-3/16"	1/2"	1	3-1/2"
R2703	1/2"	2"	1/2"	1	4-1/2"
R2704	3/8"	1"	1/4"	2	3"
R2705	3/8"	1"	3/8"	2	3"
R2706	1/2"	1-1/4"	1/2"	2	3-3/4"
R2707	1/2"	2"	1/2"	2	4-1/2"

R2710 SOLID CARBIDE ENGRAVING BITS THREE FLUTES

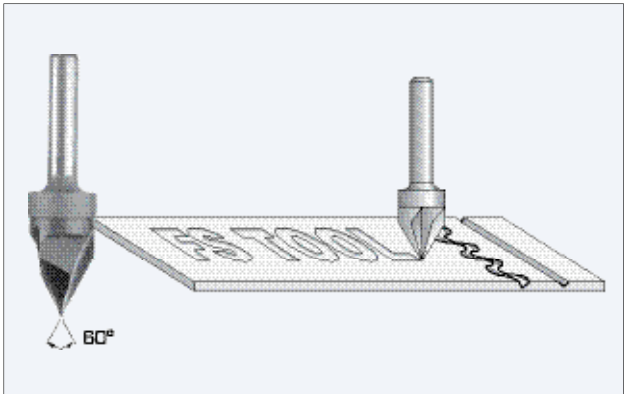

PART NO.	CUTTING DIAM.	CUTTING DEPTH	SHANK DIAM.	OVERALL LENGTH
R2710	9/16"	7/8"	1/4"	2-1/4"